

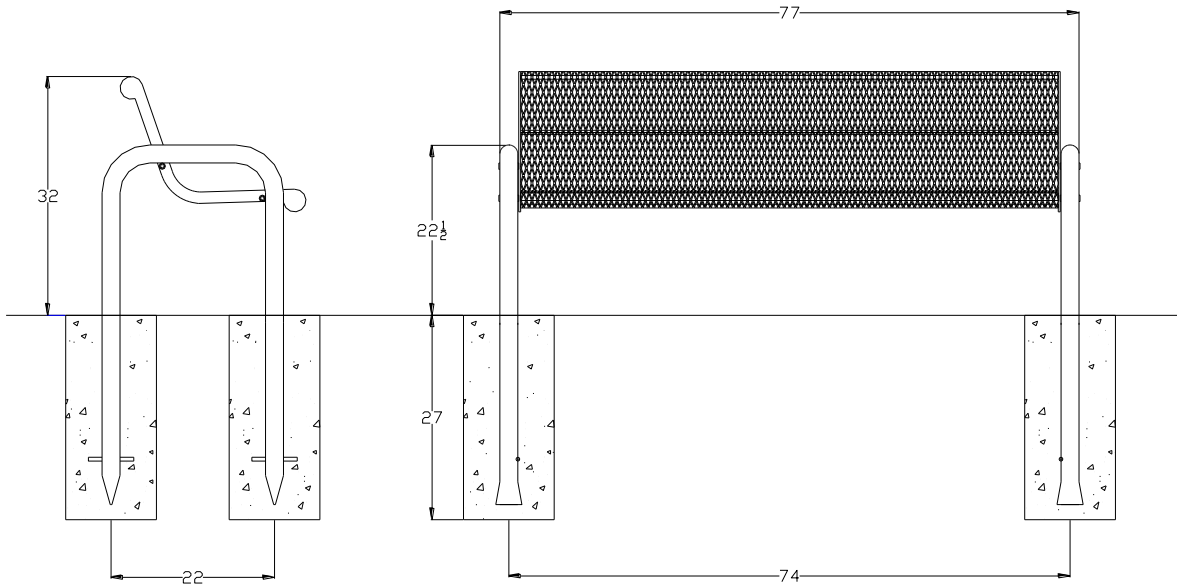

974-302



Part No.	Description	Qty.
623-015	6' Grand Contour Exp Seat	1
733-212	Grand Contour Stand	2
516-033	3/8" X 4" SS Btn Skt Cap	4
516-028	3/8" SS Nylock Nut	4
516-023	3/8" SS Washer	8

- 1 Drill plastic out of the mounting holes on the seat and stands using a 7/16" dia. drill bit.
- 2 Fasten the seat to the stands.
- 3 Tighten all of the bolts.
- 4 Position bench where desired and drill holes in the ground accordingly.
- 5 Put legs into holes and support the bench so that it's level end to end and the top of the stands are level front to back.

In Accordance to California law: WARNING This product contains a chemical known to the State of California to cause cancer and birth defects or other reproductive harm.

Periodic check of bolt tightness recommended.



PREMIER POLYSTEEL

The Best Commercial Outdoor Furniture Available. Period.

