

4' Grand Contour Laser Bench, Free Standing

971-103

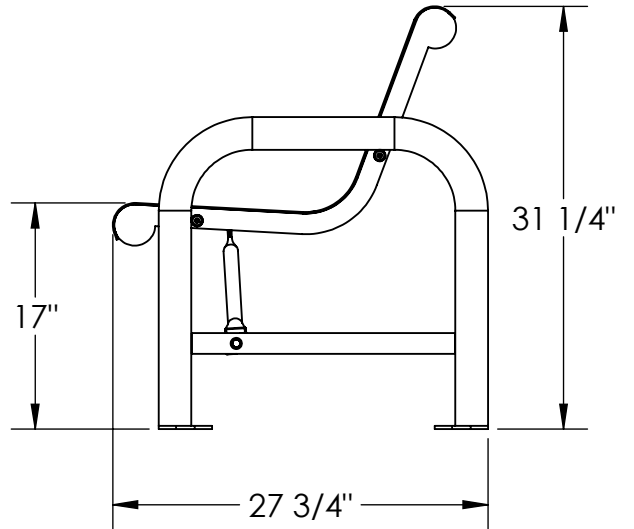

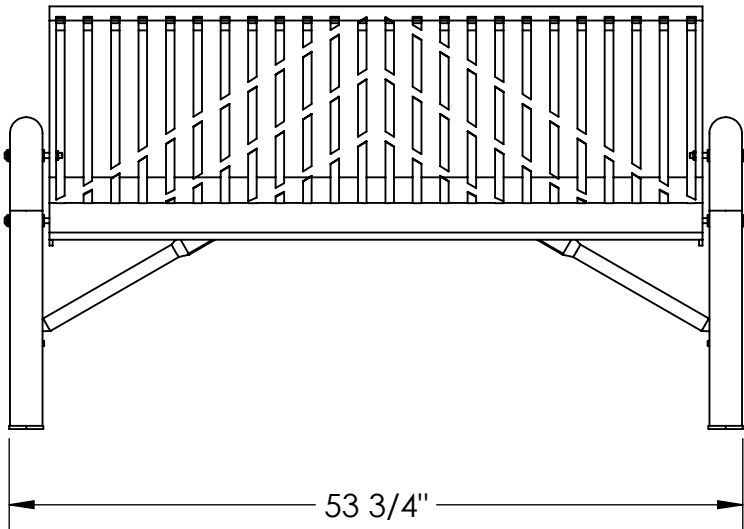
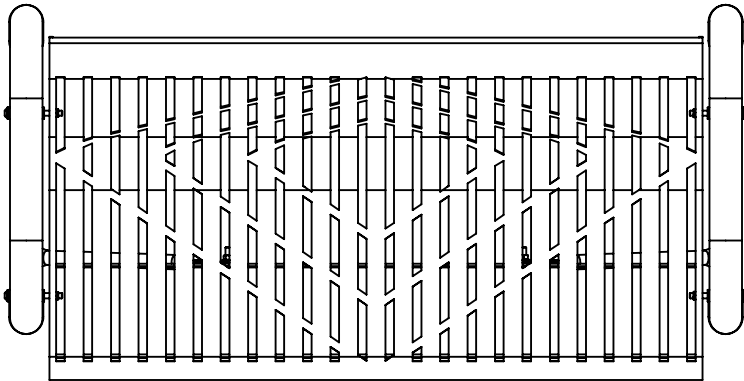
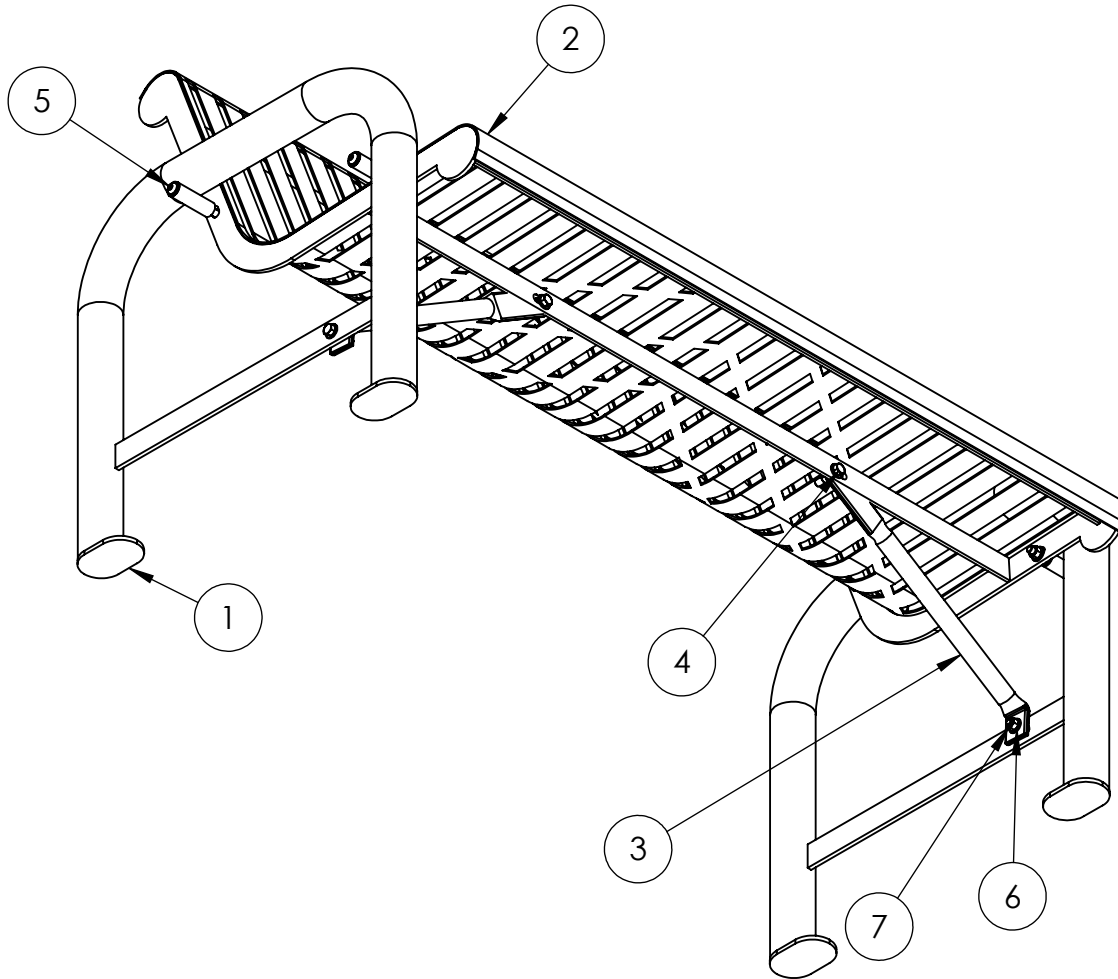

1. Drill plastic out of the mounting holes on the seat, braces and stands using a 7/16" dia. drill bit.
2. Fasten the seat to the stands loosely, then attach the braces to the seat and stands loosely.
3. Make sure stands, seat and braces are aligned, then tighten all of the bolts.
4. Position bench where desired and mount to surface if desired.

ITEM NO.	PART NUMBER	DESCRIPTION	QTY.
1	733-013	Grand Contour Free Standing Bench Stand	2
2	625-004	4' Grand Contour Laser Bench	1
3	631-313	Brace for FS Bench	2
4	516-058	3/8"x1-1/2" SS Hex Bolt	4
5	516-033	3/8"x4" SS Button Head Cap Screw	4
6	516-023	3/8" SS Flat Washer	16
7	516-028	3/8" SS Nylock Nut	8



**PREMIER POLYSTEEL**  
The Best Commercial Outdoor Furniture Available. Period.

