

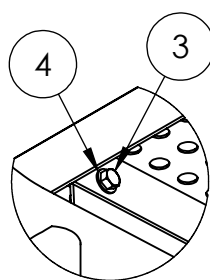

6' CHAMPION BENCH WITH BACK, SURFACE MOUNT

947-3P7

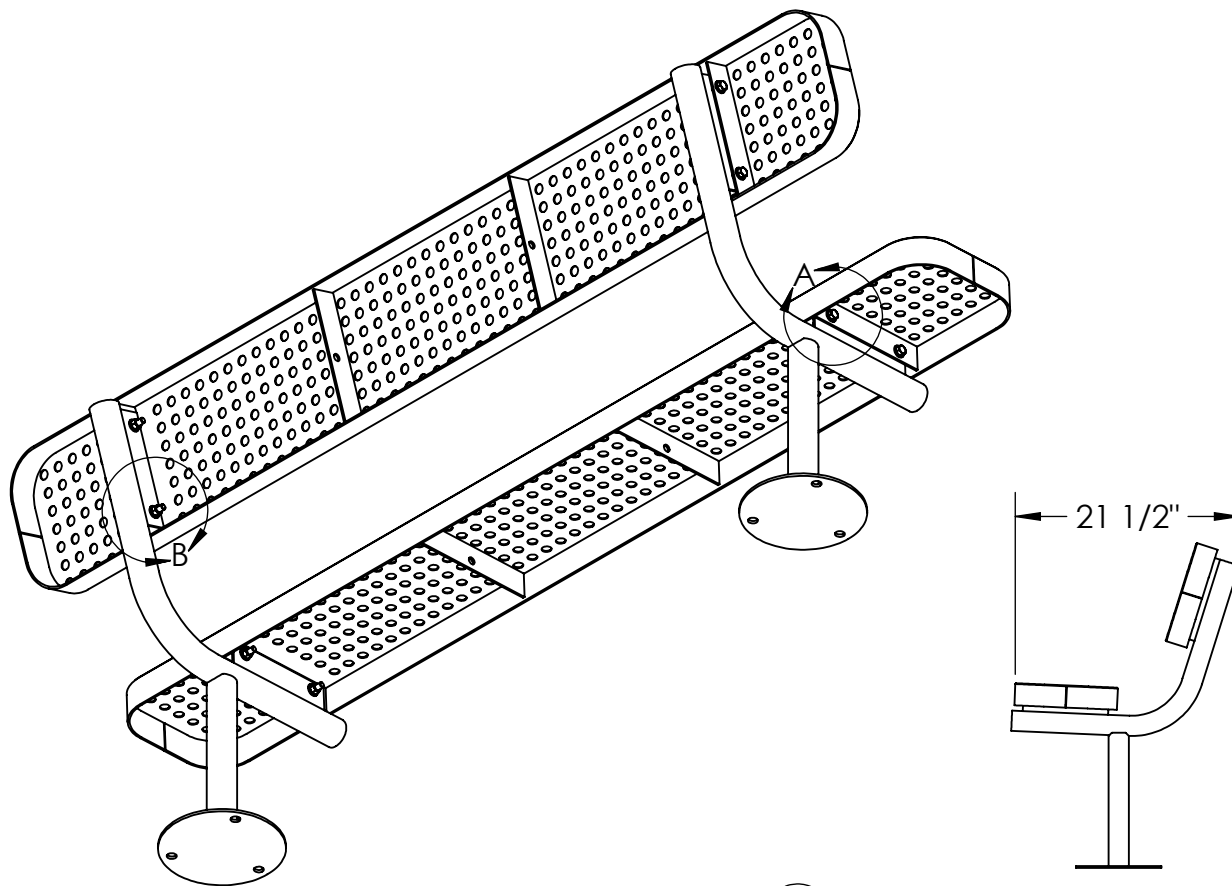

DETAIL A
SCALE 1 : 6

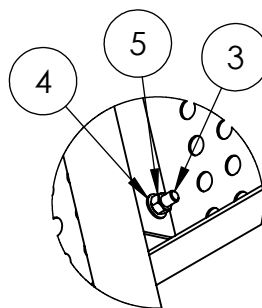

DETAIL B
SCALE 1 : 6

Tools List

- 7/16" Drill bit
- 9/16" Socket
- 9/16" Wrench
- 7/32" Allen Wrench
- Impact Gun (Optional)
- Drill

Periodic check of bolts tightness recommended



PREMIER POLYSTEEL

The Best Commercial Outdoor Furniture Available. Period.

