

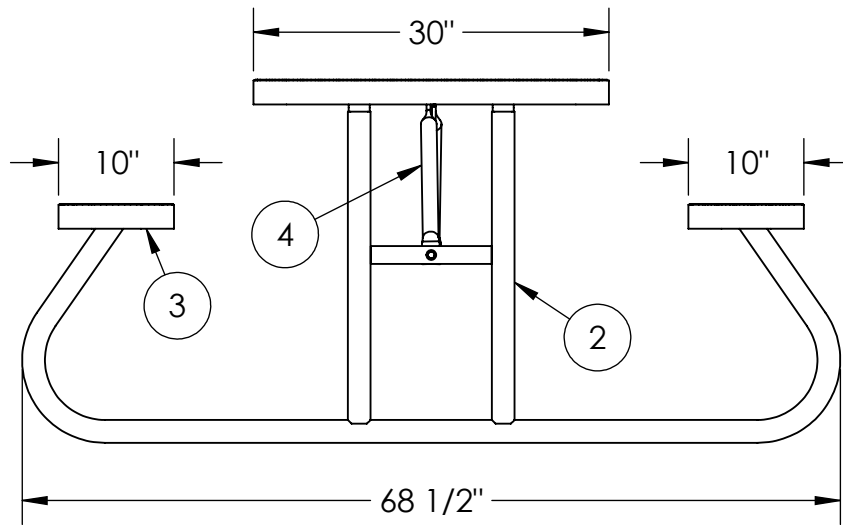

8' Champion Expanded Metal Free Standing Picnic Table

924-501

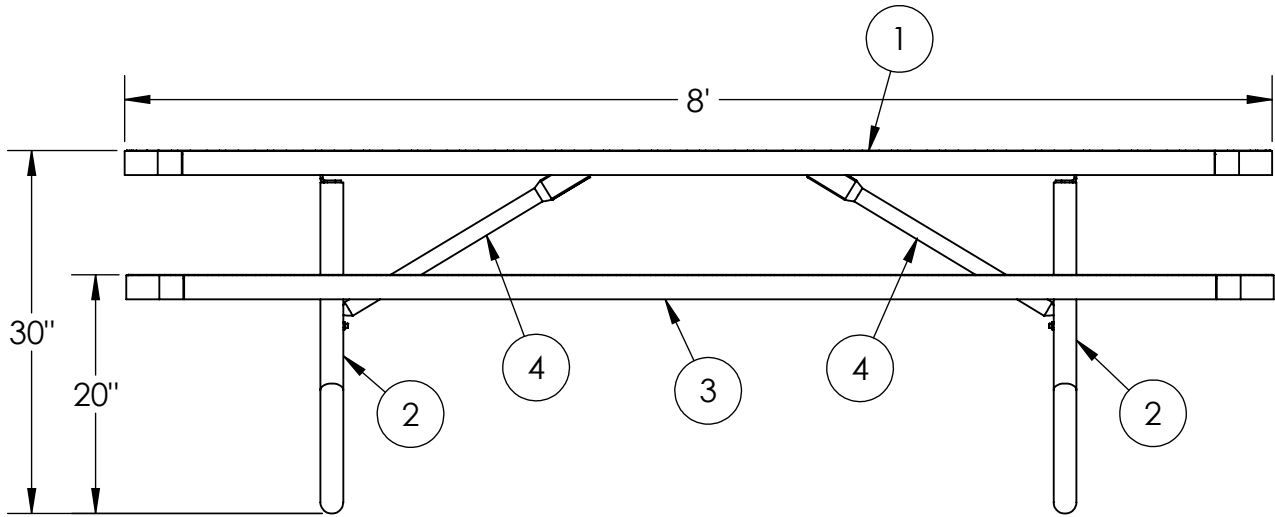

ITEM NO.	PART NUMBER	DESCRIPTION	QTY.
1	642-015	8' Champion Table Top (QS)	1
2	634-010	Free Standing Table Stand For Seats	2
3	622-015	8' Champion Seat/Back (QS)	2
4	634-013A	Table Brace	2
5	516-058	3/8"x1-1/2" SS Hex Bolt	16
6	516-023	3/8" SS Flat Washer	32
7	516-028	3/8" SS Nylock Nut	16



PREMIER POLYSTEEL

The Best Commercial Outdoor Furniture Available. Period.



SIZE
A

REV. X.01 SHEET 1 OF 2

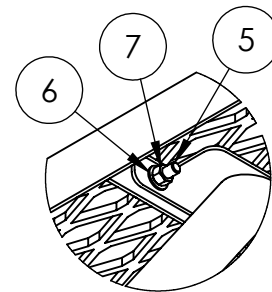
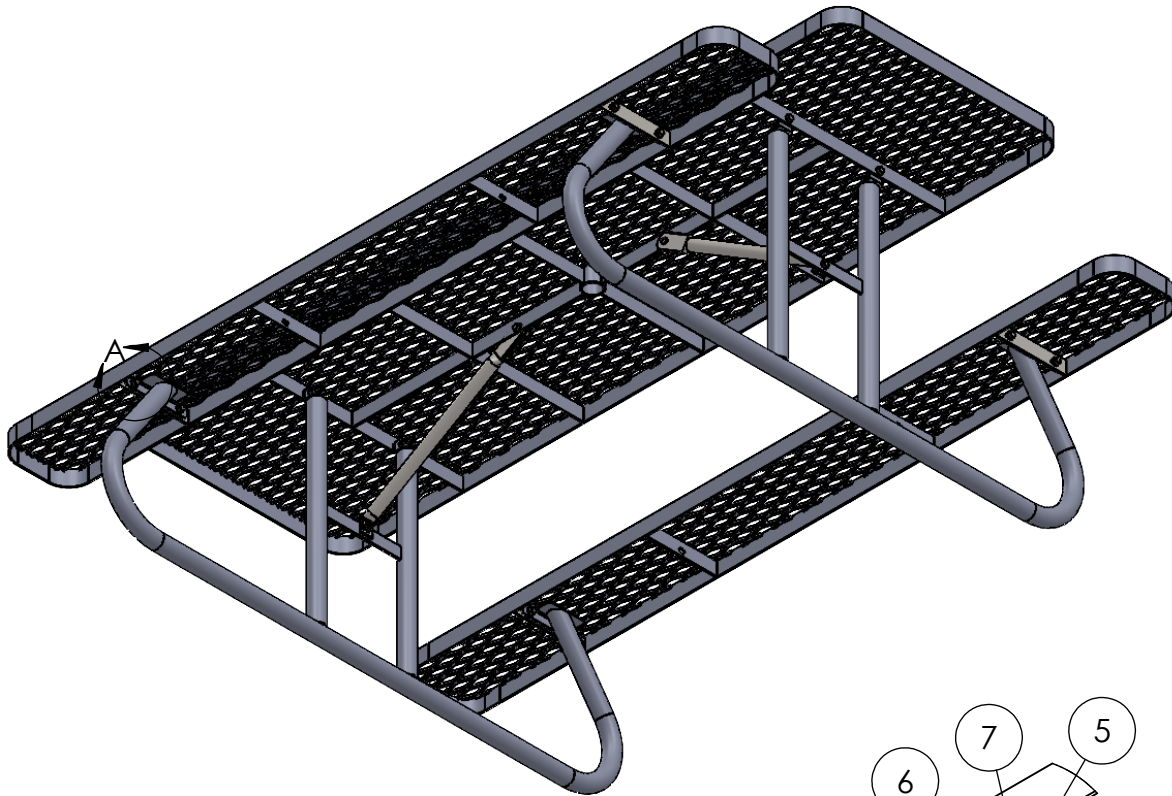

DETAIL A
SCALE 1 : 6

Tools List

- 7/16" Drill bit
- 9/16" Socket
- 9/16" Wrench
- 7/32" Allen Wrench
- Drill

1. Drill plastic out of the holes using a 7/16" diameter drill bit.
2. Attach both legs to the inside of the table support bar (see view above).
3. Attach the seats to the legs.
4. Attach the straight end of each brace to the table (see view above).
5. Attach the bent end of each brace to the cross bar of each leg (see view above).
6. Tighten up all fixings.

Periodic check of bolts tightness recommended

In accordance to California law: WARNING - This product contains a chemical known to the State of California to cause cancer and birth defects or other reproductive harm.



PREMIER POLYSTEEL

The Best Commercial Outdoor Furniture Available. Period.

