

ITEM NO.	PART NUMBER	DESCRIPTION	Default/QTY.
1	670-004	Lounge Chair Base Frame	1
2	670-002	Lounge Chair Seat	1
3	670-012	Chaise Lounge Back	1
4	670-014	Chaise Lounge Brace	1
5	520-100	Chaise Lounge Chair Wheel	2
6	520-110	1/2" Axle Cap	2
7	516-031	3/8"x1-3/4" SS Btn Skt Cap Screw	2
8	516-032	3/8"x3-1/2" SS Button Head Cap Screw	2
9	516-068	1/2"X2" SS Button Head Cap Screw	2
10	516-067	1/2"X2-1/2" SS Button Head Cap Screw	2
11	516-023	3/8" SS Flat Washer	8
12	516-028	3/8" SS Nylock Nut	4
13	516-027	1/2" SS Flat Washer	12
14	516-036	1/2" SS NyLock Nut	4

900-101

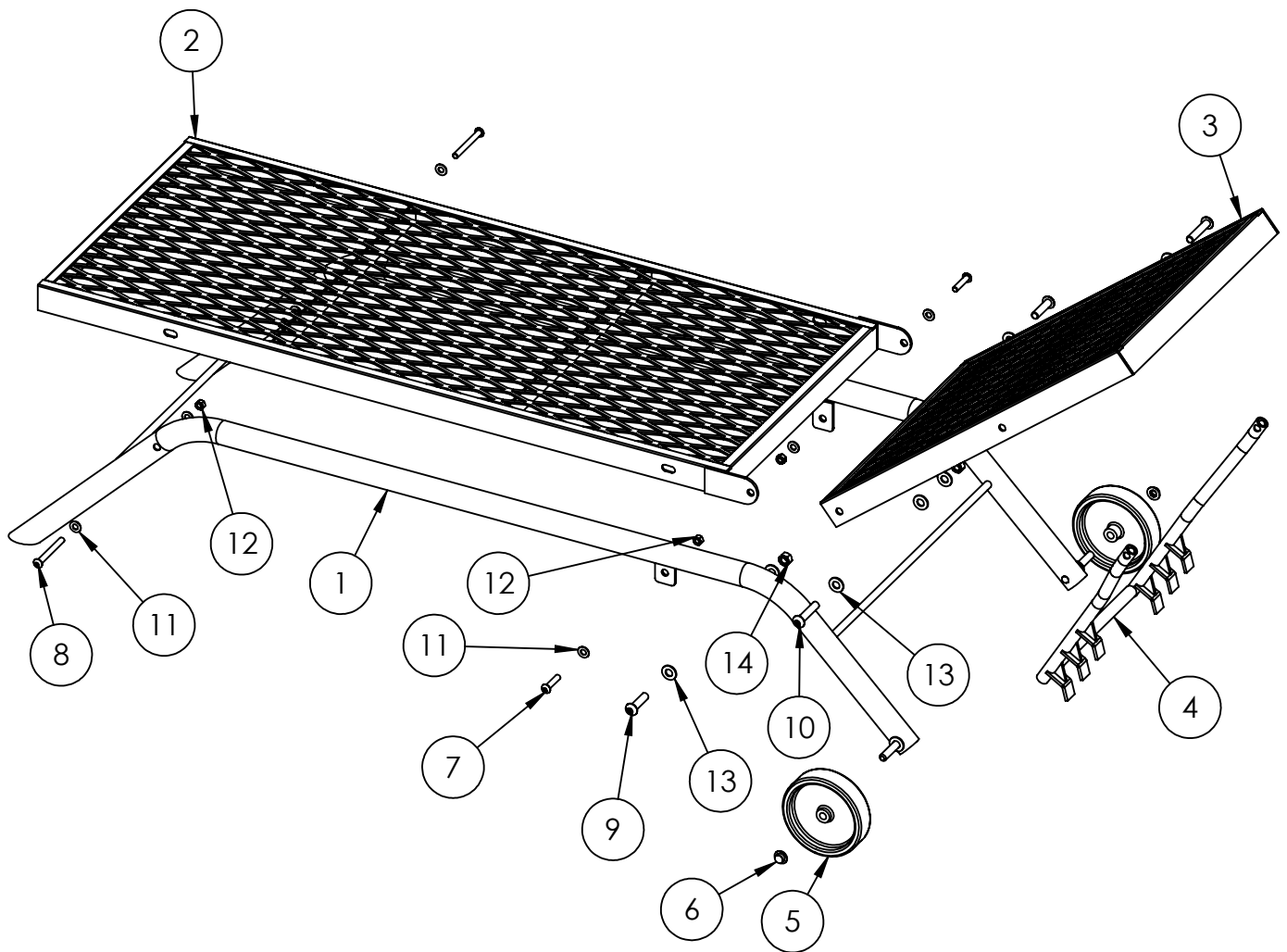

PREMIER POLYSTEEL

The Best Commercial Outdoor Furniture Available. Period.



SIZE
A

REV. X.01 | SHEET 1 OF 3

Tools needed:

900-101

3/8" & 1/2" Drill Bit. Electric Drill
Pliers
5/16" & 7/32" Hex Wrench
9/16" & 3/4" Socket & ratchet or 9/16" & 3/4"
Box End Wrench
Hammer



1. With the 3/8" drill bit
2. With a 1/2" drill bit, drill out the 2 holes on the base where the back connects. Also drill out the 4 holes on the back where it connects to the base and the brace. The holes on the brace should be drilled out at this time too.
3. Attach the back to the base using the (2) 1/2"x2" Socket Head Cap Screws. Place a washer on the cap screw and insert it into the base, place another washer on the cap screw between the base and the back. Now push the cap screw through the back and attach a washer & locknut. Do not tighten at this time. Repeat step 2 for opposite side of the base. Now tighten the cap screws so that the back will swing freely up and down.
4. Attach the brace to the back using the (2) 1/2"x2-1/2" Socket Head Cap Screws. Place a washer on the cap screw and insert it into the back, place another washer on the cap screw between the back and the brace. Push the cap screw through the brace and place another washer on the cap screw & a locknut. Do not tighten at this time. Repeat step 3 for the opposite side of the back. Now tighten the cap screws so that the brace swings freely.
5. Using a pliers grab the plastic coating on the axle and twist & pull it off. Place a washer on the axle, then install the wheel. Now place the axle cap on the axle and tap it on with a hammer.

In Accordance to California law: WARNING This product contains a chemical know to the State of California to cause cancer and birth defects or other reproductive harm.

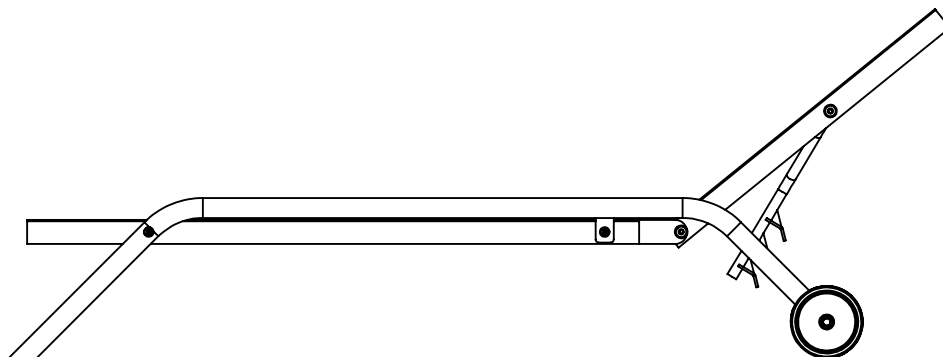
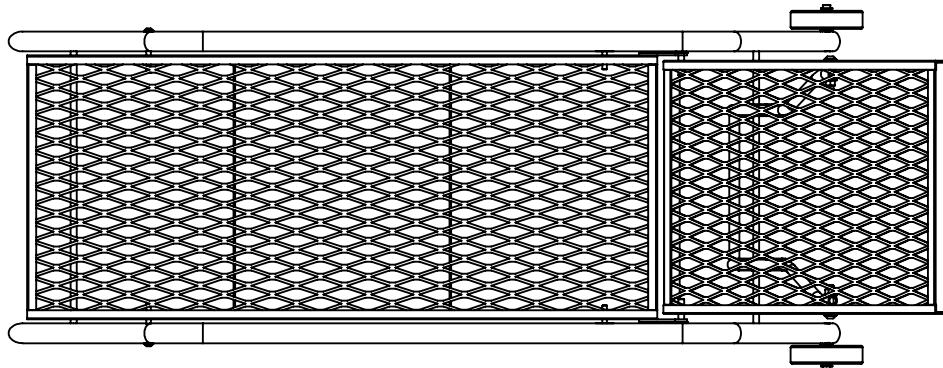

PREMIER POLYSTEEL

The Best Commercial Outdoor Furniture Available. Period.



SIZE
A

REV. X.01 SHEET 2 OF 3

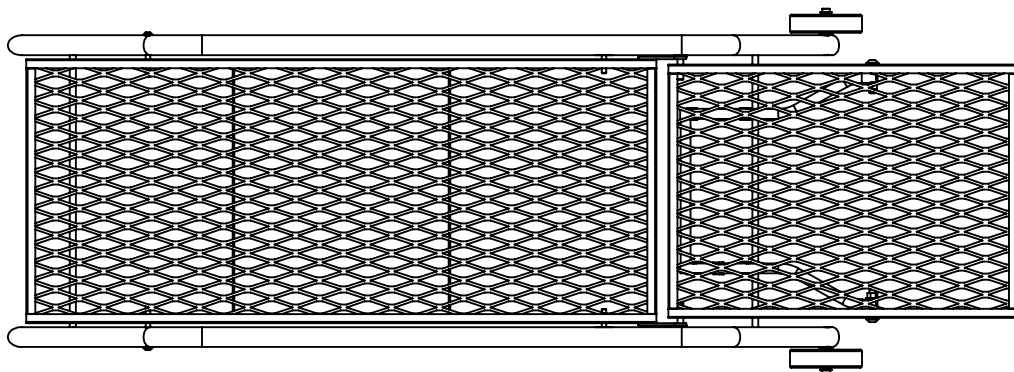
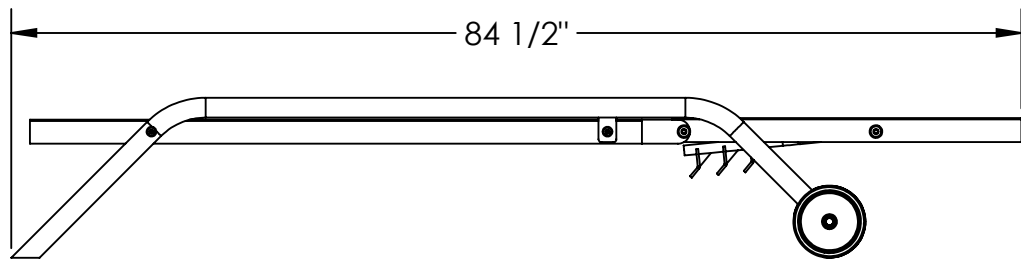
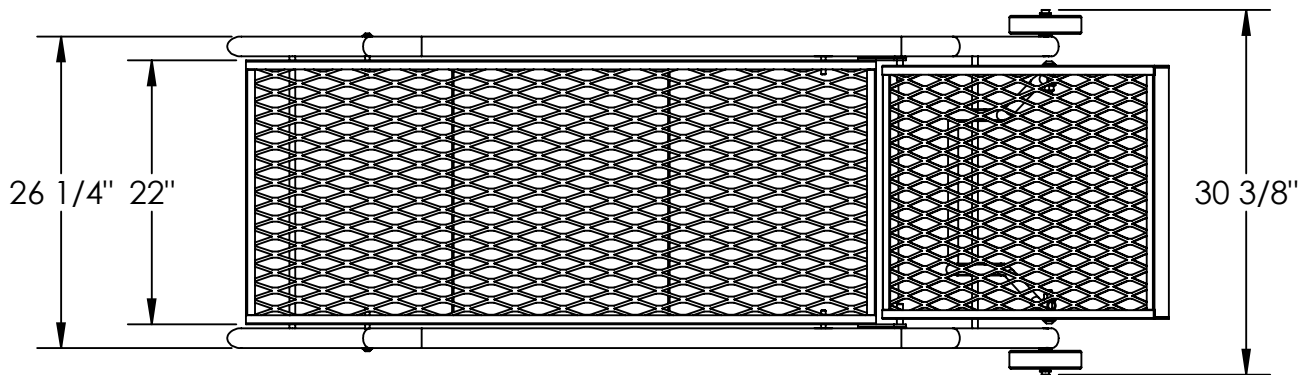
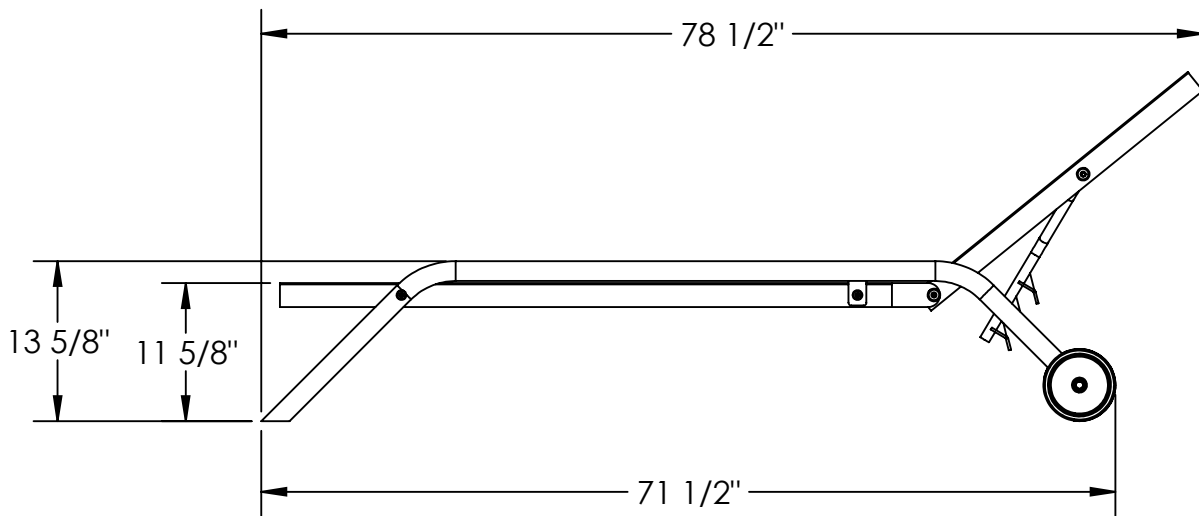

PREMIER POLYSTEEL

The Best Commercial Outdoor Furniture Available. Period.

