

4' Grand Contour Laser Bench, Free Standing

971-103

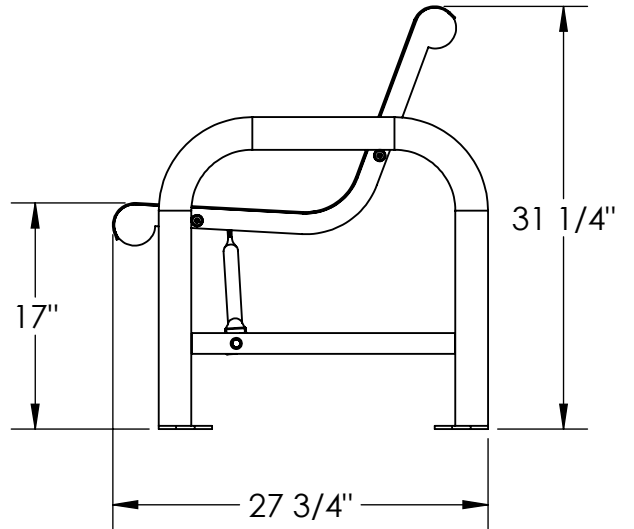
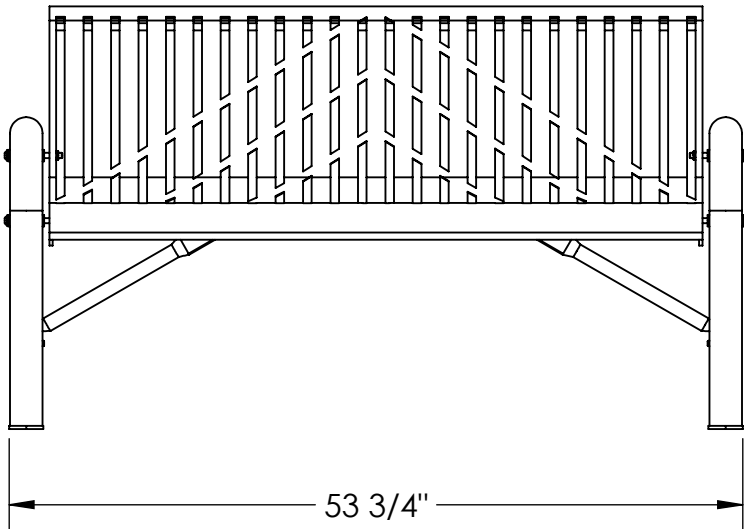
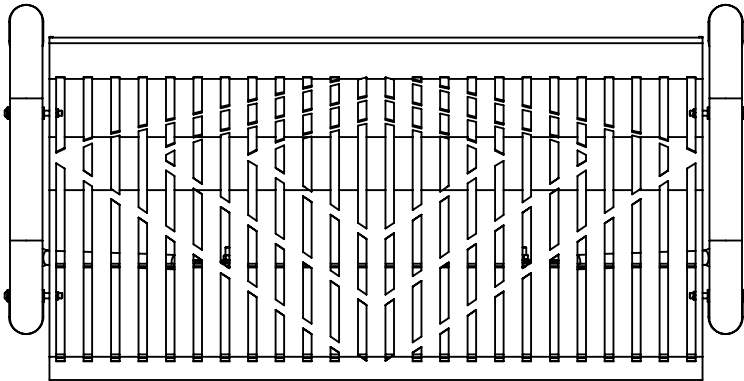

PREMIER POLYSTEEL

The Best Commercial Outdoor Furniture Available. Period.



SIZE
A

REV. X.01 SHEET 1 OF 2

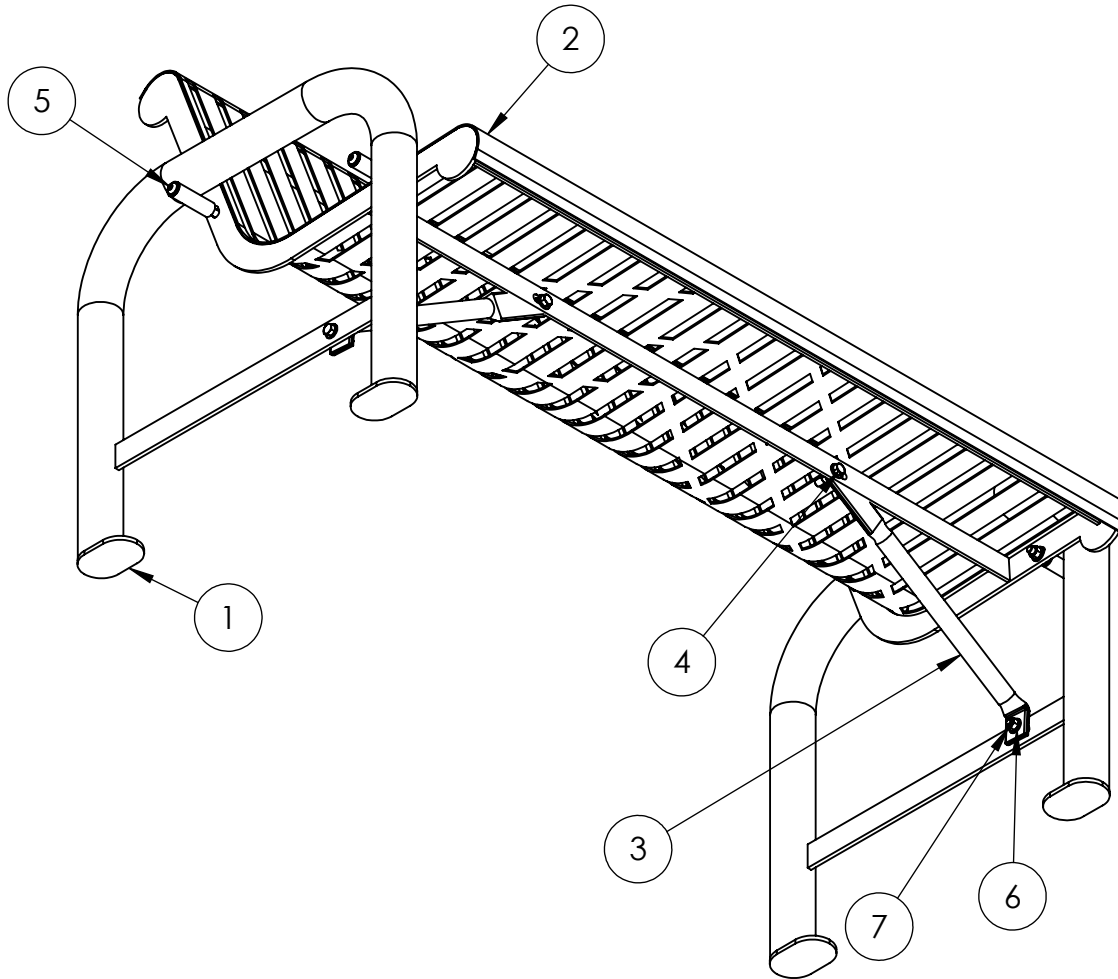

In Accordance to California law: WARNING This product contains a chemical know to the State of California to cause cancer and birth defects or other reproductive harm.

1. Drill plastic out of the mounting holes on the seat, braces and stands using a 7/16" dia. drill bit.
2. Fasten the seat to the stands loosely, then attach the braces to the seat and stands loosely.
3. Make sure stands, seat and braces are aligned, then tighten all of the bolts.
4. Position bench where desired and mount to surface if desired.

ITEM NO.	PART NUMBER	DESCRIPTION	QTY.
1	733-013	Grand Contour Free Standing Bench Stand	2
2	625-004	4' Grand Contour Laser Bench	1
3	631-313	Brace for FS Bench	2
4	516-058	3/8"x1-1/2" SS Hex Bolt	4
5	516-033	3/8"x4" SS Button Head Cap Screw	4
6	516-023	3/8" SS Flat Washer	16
7	516-028	3/8" SS Nylock Nut	8



PREMIER POLYSTEEL

The Best Commercial Outdoor Furniture Available. Period.



4' Grand Contour Bench, Free Standing Expanded Metal

974-103

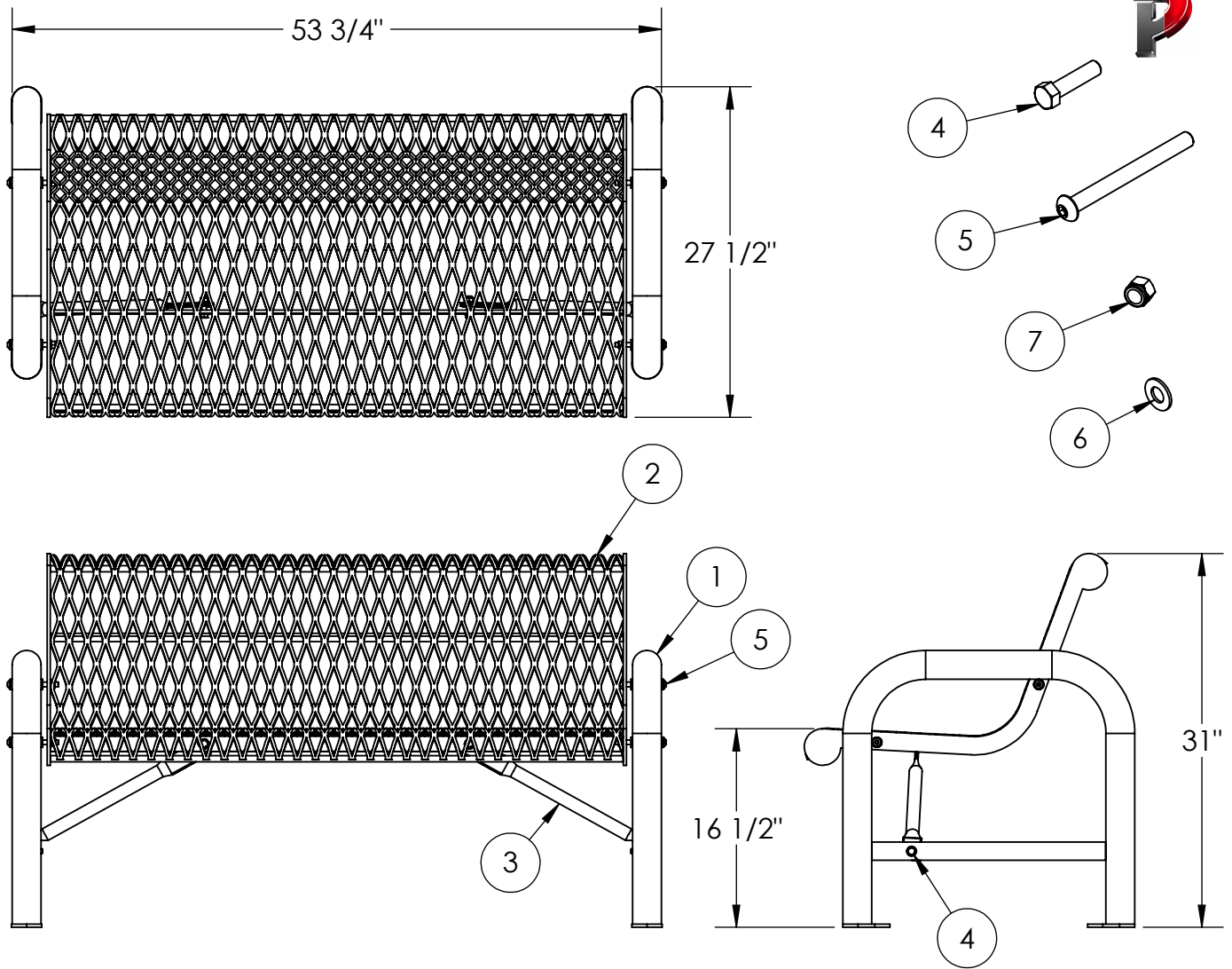

1. Drill plastic out of the mounting holes on the seat, braces and stands using a 7/16" dia. drill bit.
2. Fasten the seat to the stands loosely and then fasten the brace to the stands and seat.
3. Make sure the bench is level and tighten all the bolts.
4. Position bench where desired and anchor to the floor.

In Accordance to California law: WARNING This product contains a chemical know to the State of California to cause cancer and birth defects or other reproductive harm.

ITEM NO.	PART NUMBER	DESCRIPTION	QTY.
1	733-013	Grand Contour Free Standing Bench Stand	2
2	623-014	4' Grand Contour Expanded Metal Seat	1
3	631-313	Brace for FS Bench	2
4	516-058	3/8"x1-1/2" SS Hex Bolt	4
5	516-033	3/8"x4" SS Button Head Cap Screw	4
6	516-023	3/8" SS Flat Washer	16
7	516-028	3/8" SS Nylock Nut	8



PREMIER POLYSTEEL

The Best Commercial Outdoor Furniture Available. Period.



SIZE
A

REV. X.01 | SHEET 1 OF 1



939-103

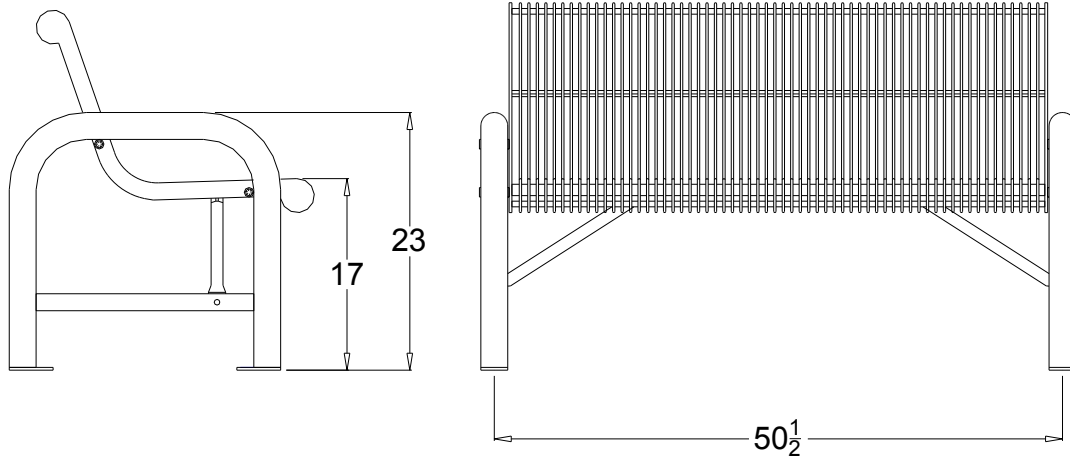

Part No.	Description	Qty.
623-004	4' Grand Contour Seat	1
733-013	Grand Contour Stand	2
631-313	Brace	2
516-033	3/8"x4" SS Button Socket Cap	4
516-058	3/8" X 1-1/2" SS Hex Bolt	4
516-028	3/8" SS Nylock Nuts	8
516-023	3/8" SS Flat Washer	16

In Accordance to California law: WARNING This product contains a chemical know to the State of California to cause cancer and birth defects or other reproductive harm.

- 1 Drill plastic out of the mounting holes on the seat, braces and stands using a 7/16" dia. drill bit.
- 2 Fasten the seat to the stands, then attach the braces to the seat and stands.
- 3 Make sure stands, seat and braces are aligned, then tighten all of the bolts.
- 4 Position bench where desired and mount to surface.

Periodic check of bolt tightness is recommended.



PREMIER POLYSTEEL

The Best Commercial Outdoor Furniture Available. Period.

